

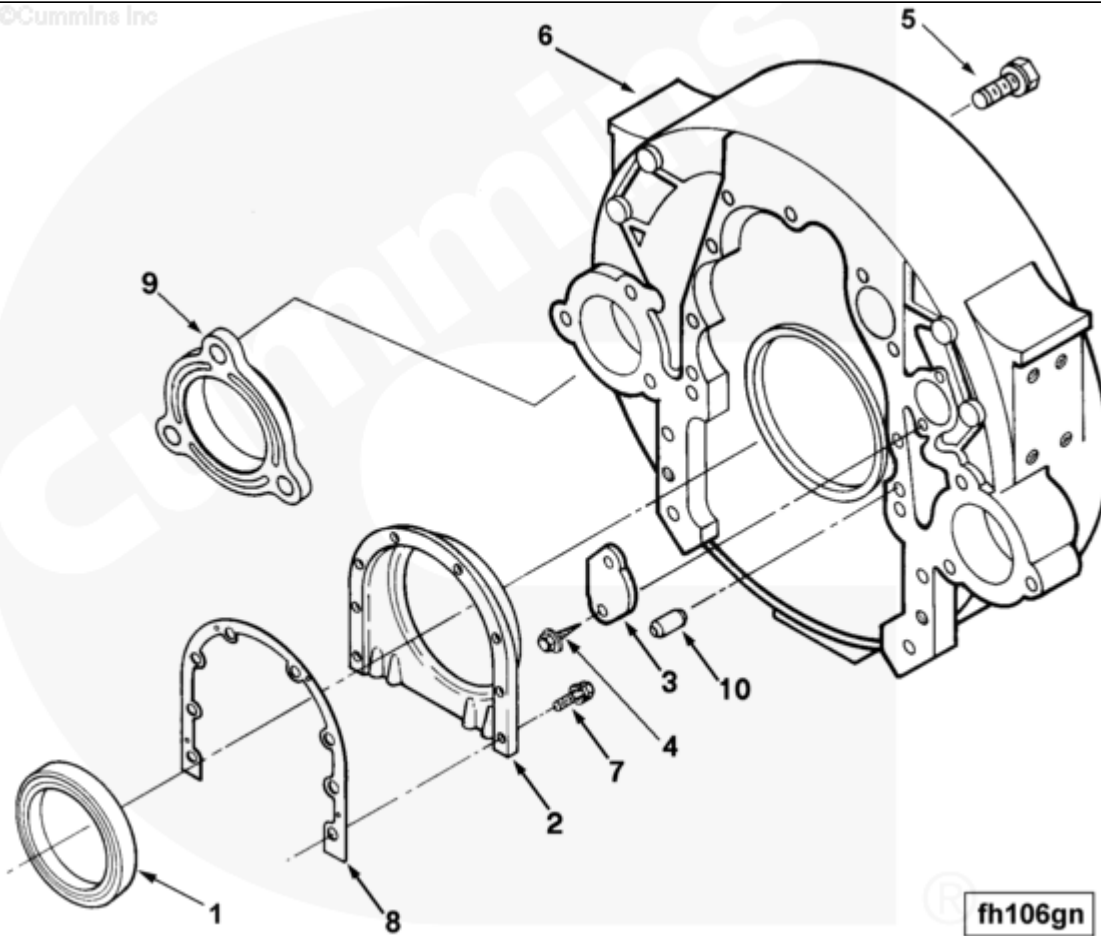

Parts Catalog - Option Detail

Electronic Parts Catalog - Option Detail				
Option	Group	Graphic	Film Card	Date
FH1127	16.01	fh106gn	F	15-SEP-96
Engines	NH/NT 855, NT495, NT743, NTA855 N106			

©Cummins Inc



[SMALL](#) | [MEDIUM](#) | [LARGE](#)

Cart	Ref No	Part Number	Part Description	Required	Remarks
View My Cart					
		FH1127	Flywheel Housing		SAE #1 dry type, closed, cast...(More)
					iron flywheel housing with
					both high and low mounting
					pads machined. Starter bore

					machined exhaust side only.
					Has provision for magnetic
					pickup. Option includes thick
					starter spacer for
					conventional ring gear
					location.
<input type="checkbox"/>	1	3006737	Oil Seal	1	
<input type="checkbox"/>	2	3049018	Rear Cover	1	
<input type="checkbox"/>	3	70657	Access Hole Cover	1	
<input type="checkbox"/>	4	3011342	Captive Washer Cap Screw	2	1/4 - 20 x 3/4 in.
<input type="checkbox"/>	5	3048351	Captive Washer Cap Screw	9	5/8 - 18 X 1 1/2 Inch.
<input type="checkbox"/>	6	3005557	Flywheel Housing	1	
<input type="checkbox"/>	7	3010594	Captive Washer Cap Screw	8	3/8 - 24 x 1 1/2 inch
<input type="checkbox"/>	8	3067616	Rear Cover Gasket	1	
<input type="checkbox"/>	9	9245	Starting Motor Spacer	1	
<input type="checkbox"/>	10	60408	Pin Dowel	2	